



Z33-M060.05 S1

Manual tool change

Item no. **10200031**

HF-Spindle for high-speed milling, -grinding, -drilling, -engraving

Bearings

Hybrid ball bearing (pcs)	2 (front)
Steel ball bearing (pcs)	1 (rear)
Lifetime lubricated	maintenance free

Motor

Motor technology	3-phase asynchronous drive (no brushes or sensors)
Frequency	1.000 Hz
Motor poles (pairs)	1
Rated rotation speed	60.000 rpm
Acceleration/braking value Per second	10 000 rpm (other values by consultation)

Power values

Uncooled

	Pmax./5s	S6-60%	S1-100%	
Rated power	0,24	0,24	0,18	[kW]
Torque	0,059	0,047	0,036	[Nm]
Voltage	46	46	44	[V]
Current	6,5	6,5	5,5	[A]

Z33-M060.05 S1

Manual tool change
Item no. **10200031**

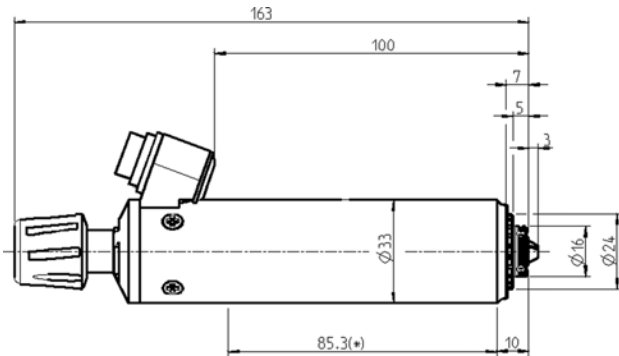

Dimensions

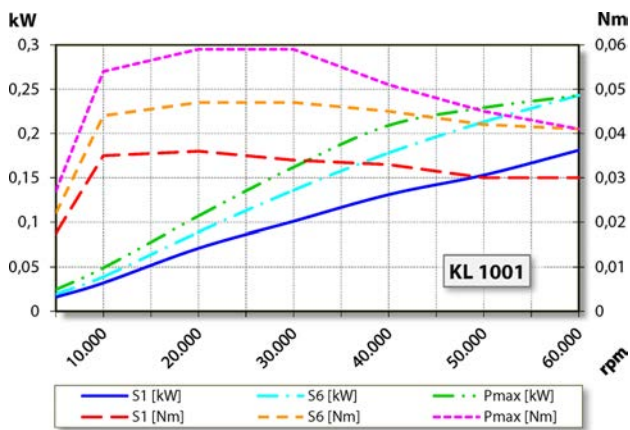

Performance Diagram

Uncooled

Measurement of power is funded by in-house testing.

Characteristics

Housing	Stainless steel
Housing diameter	33 mm
Cooling	Uncooled
Heat dissipation	Via the spindle holder
Housing temperature	< + 45° C
Ambient temperature	+ 10°C ... + 45°C
Protection category	IP43
Tool change	Manual tool change
Collet type	5,5H
Clamping range up to	3.5 mm (1/8")
Rotation	Clockwise
Coupler plug	3-pin (Amphenol C 091 A)
Weight	~ 0,5 kg
Inner taper run out	< 1 μ